



PMT MOUSETRAP MOTION MOUNT

USER GUIDE

Description	Part Number
PMT Mousetrap	AS5.N101.002
PMT Mousetrap with Low Profile Tilt	AS5.N101.006
PMT Mousetrap with Wedge Tilt	AS5.N101.003
PMT Mousetrap with Adjustable Multi-Pattern Tilt	AS5.N101.009

Product Mounting Disclaimer

Precision Mounting Technologies Ltd (PMT) are not liable under any theory of contract or tort law for any loss, damage, personal injury, special, incidental or consequential damages for personal injury or other damage of any nature arising directly or indirectly as a result of the improper installation or use of its products in vehicle or any other application. In order to safely install and use PMT products full consideration of vehicle occupants, vehicle systems (i.e., the location of fuel lines, brake lines, electrical, drive train or other systems), air-bags and other safety equipment is required. PMT specifically disclaims any responsibility for the improper use or installation of its products not consistent with original vehicle manufactures' specifications and recommendations, PMT product instruction sheets, or workmanship standards as endorsed through PMT policies and EULA.



LOCATION AND DESCRIPTION OF PARTS

Bottom view:

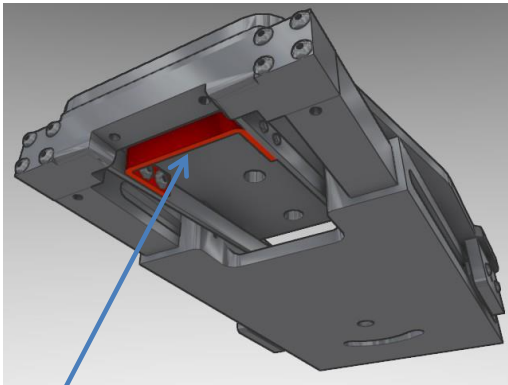

B. Slide Trigger Release

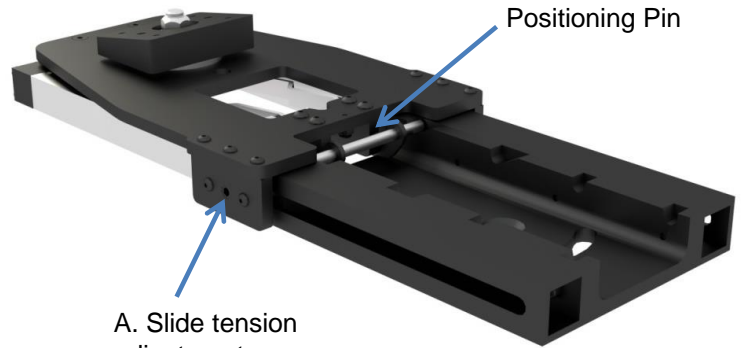

Positioning Pin

A. Slide tension adjustment screw

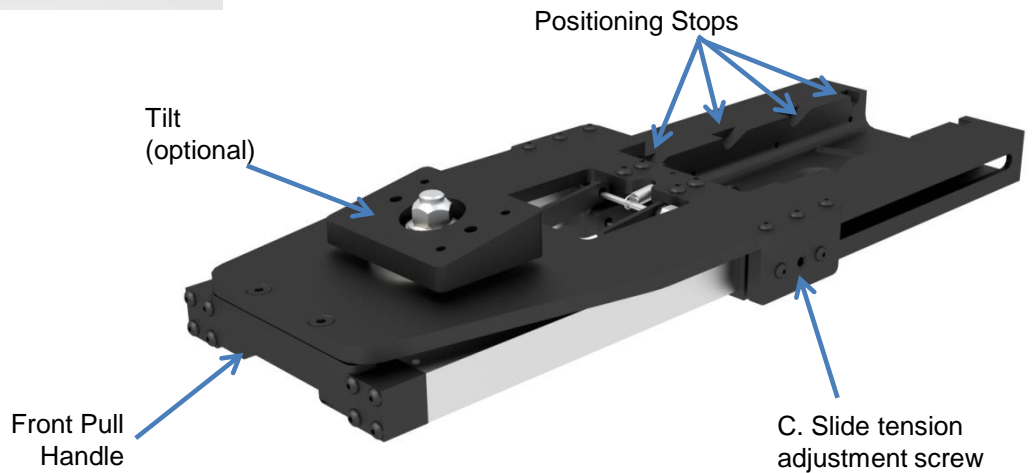

Positioning Stops

Tilt (optional)

Front Pull Handle

C. Slide tension adjustment screw

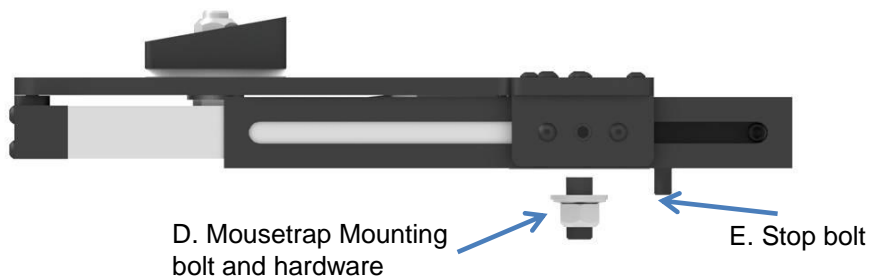

D. Mousetrap Mounting bolt and hardware

E. Stop bolt

LOCATION AND DESCRIPTION OF PARTS

Bottom view
(shown fully
extended):

Tilt device mounting bolt locations
(Torque to **15ft/lbs**)

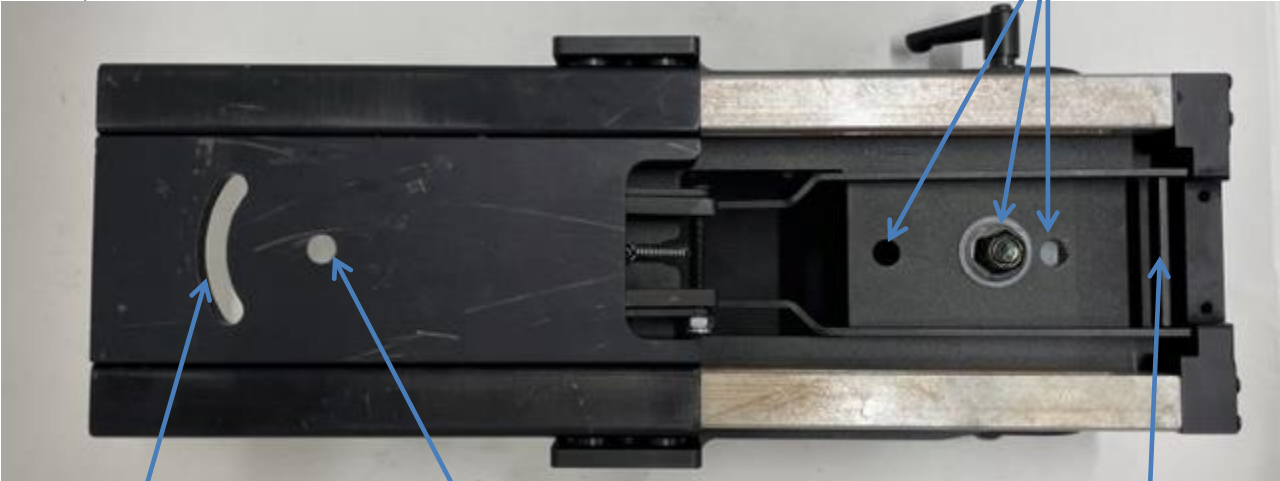

Stop Bolt arch

Mousetrap mounting bolt location

Slide Trigger release

Top view
(shown fully
extended):

Mousetrap mounting bolt and hardware
installed. (Torque to **32ft/lbs**)

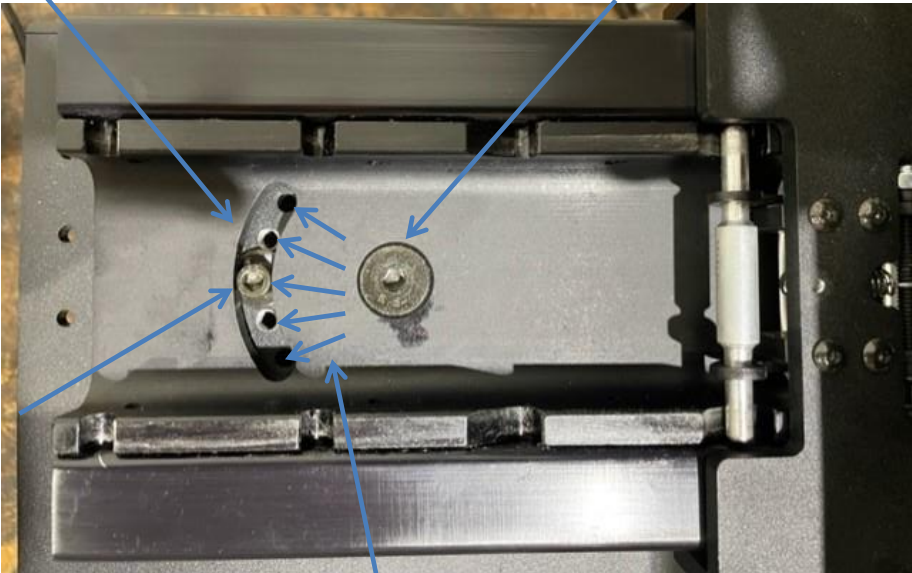

Stop Bolt installed
in standard
location (factory
default). **At least
one Stop Bolt
must be used.**

Five Stop Bolt positions on
mount (not part of Mousetrap)

INSTALLATION AND ADJUSTMENTS

1. If not already mounted from the factory, install the Mousetrap to the mounting infrastructure (bracket, console, etc) using the included 3/8"-16 flat head screw and hardware provided (Item D from pg 2). Ensure to use the locking Stover nut provided. Red Loctite 262 (or equivalent) can also be used to reduce chances of the nut backing off. Torque to **32ft/lbs** and double check swivel for proper tension. Tension should be tight enough to require reasonable force to maneuver mount, but substantial enough to not freely swivel. See image to right for proper hardware installation sequence. Note that the nylon washer is a wear item and will wear over time at a rate dependent upon usage. PMT recommends users monitor tension and adjust/re-torque as needed, but at minimum once per year.
2. If not already mounted from the factory, install at least one Stop Bolt (Item E from pg 2) in one of the 5 threaded hole locations on the mount. This position dictates how much swing/swivel the device will have and is critical to prevent the mounted device from potentially interfering with nearby equipment and controls. By utilizing two Stop Bolts the range of motion can be reduced further or can also be eliminated (only linear motion would be possible).
3. Generally, it is recommended to install the Mousetrap and mount so that the Stop Bolt Arch and matching threaded holes are facing towards the dash of a vehicle and/or away from the user. **It is mandatory that at least one stop bolt be installed and located within the Stop Bolt Arch.** Note a 1/4" flat steel washer can be used under the head of the stop bolt for more engagement with the Stop Bolt Arch, but is not mandatory.
4. If not already mounted from the factory, attach a Tilt bracket option to one of the three locations provided at the front of the Mousetrap. Which hole to use is determined by size of mounted device and position of where the Mousetrap is installed relative to other equipment to reduce interference. Attach using the supplied 3/8"-16 hardware and red Loctite 262 (or equivalent) and torque to **15ft/lbs**. Note that the nylon washer is a wear item and will wear over time at a rate dependent upon usage. PMT recommends users monitor tension and adjust/re-torque as needed, but at minimum once per year.

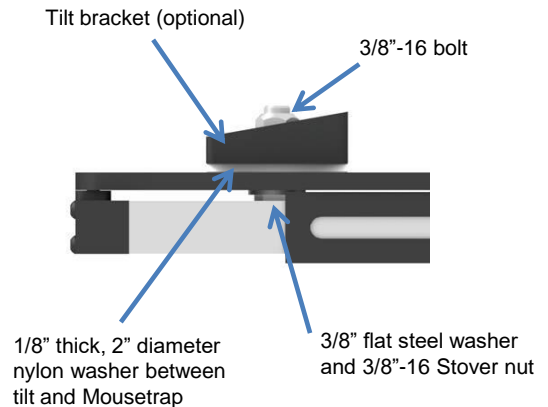
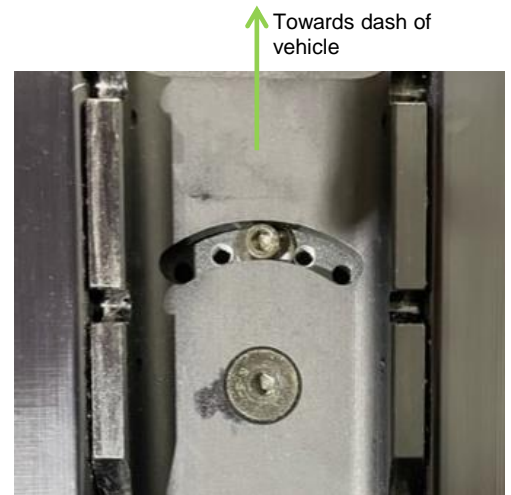
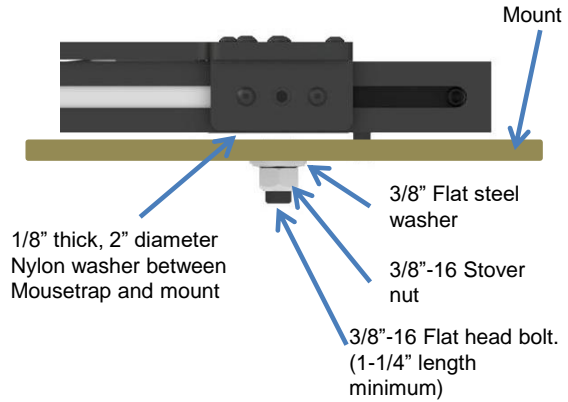

ADJUSTMENTS AND USE

1. Adjust slide tension (if necessary) to reduce vibration and increase or decrease linear slide resistance. Note that factory default setting is loose for maximum safety to allow for auto-retract in the event of an emergency. Adjust by tightening or loosening set screws with a 5/32" Allen/Hex key wrench. Repeat on opposite side for proper tension.
2. To extend the Mousetrap, squeeze the Release Trigger located behind the front handle with two fingers. Pull the device towards you and release. **DO NOT OPERATE/DRIVE VEHICLE WITH MOUSETRAP EXTENDED.** To retract the device, simply push against the front handle. No release buttons or triggers are required to retract.
3. Further adjust the device by swinging the entire Mousetrap left or right, and also swivel the mounted device via the Tilt bracket for better comfort and ergonomics. **ENSURE DEVICE DOES NOT INTERFERE WITH OTHER EQUIPMENT OR VEHICLE CONTROLS.** If it does interfere, go back and reposition/adjust stop bolts and general position of tilt, and Mousetrap.

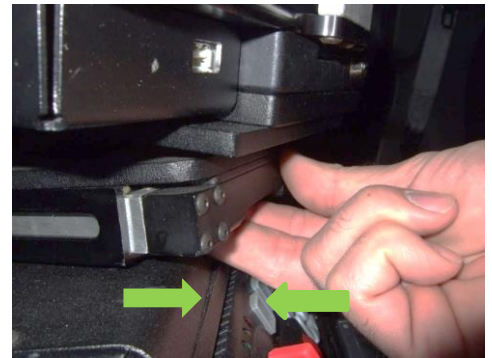
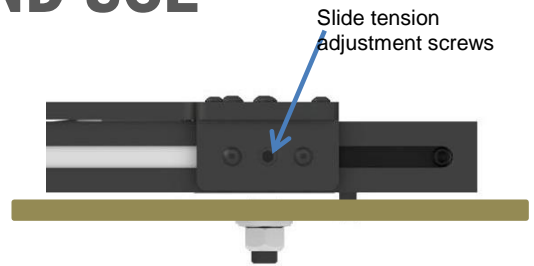

Squeeze Release Trigger to extend



Extend

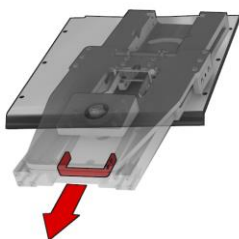

Squeeze Release Trigger, pull forward

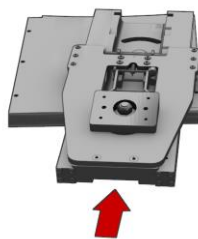

Push to retract

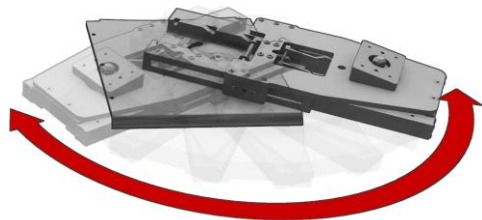

Swing left/right, swivel left/right